

EFFICIENT DEPTH IMAGE BASED RENDERING WITH EDGE DEPENDENT DEPTH FILTER AND INTERPOLATION

Wan-Yu Chen, Yu-Lin Chang, Shyh-Feng Lin, Li-Fu Ding, and Liang-Gee Chen

DSP/IC Design Lab

Graduate Institute of Electronics Engineering and Department of Electrical Engineering
National Taiwan University, Taipei, Taiwan, R.O.C.

{wanyu, ylchang, shyh, lifu, lgchen}@video.ee.ntu.edu.tw

Abstract

An efficient depth image based rendering with edge dependent depth filter and interpolation is proposed. The proposed method can solve the hole-filling problem in DIBR system efficiently with high quality. The PSNR of the proposed method is better than the previous work by 6 dB. And the subjective view shows the quality is better. In addition to that, the number of instruction cycles is 3.7 percent compared with the previous work.

1. Introduction

Depth-Image-Based-Rendering(DIBR) is a key technology in advanced three dimensional television system (3D TV System)[1][2]. Traditional 3D TV system requires the transmission of two video streams, the left and right view, to construct 3D vision. Unlike the traditional method, the advanced three dimensional television system proposed a novel technology "DIBR" to provide 3D vision. DIBR uses intermediate view and intermediate depth map to render left and right view. In this way, broadcast content providers only have to transmit the video and gray level depth map of the intermediate view. It has been proven that the coding efficiency is better than the transmission of two view color video stream. Another advantage is the 2D/3D selectivity. Users can change 3D vision into 2D vision only by displaying intermediate view. The more important is that left and right views are rendered according to the users' parallax. Therefore, users can watch more comfortable 3D video by adjusting parallax of the rendered video.

Depth image is a 2D image that gives depth value to a point on an object in real scene according to its image coordinates [3]. Once intermediate image and depth image is given, any near by image can be synthesized by mapping pixel coordinates one by one according to its depth value. However, there is an essential problem in DIBR that occlusion holes appear after pixel to pixel mapping. Holes appear due to sharp horizontal changes in depth image, thus the location and size of holes differ from frame to frame. For hole-filling, average filter is commonly used [3]. However, the average filter does not preserve edge information of the interpolated area. Therefore, using average filter results in obvious artifacts at highly-textured area. This artifact is well known as rubber and sheet artifact [2]. Another novel method

uses Gaussian filter to smooth the whole depth image before 3D image warping. The method claims that the depth map after smoothing is blurred, there are fewer hole to be filled. However, if we smooth the whole depth map before warping, the computation time and the warped image quality is bad. The subjective view and PSNR of previous work are listed in the results section.

In our paper, an efficient depth-image-based-rendering with edge dependent depth filter and interpolation is proposed. Hole-location and hole-size are detected before 3D image warping. And the edge dependent Gaussian filter is used to reduce the hole-size efficiently. Then we use edge dependent interpolation to fill the small holes, thus the edge information of synthesized video is preserved.

The previous method would be introduced in the section 2. Our proposed DIBR system is illustrated in section 3. In section 4, we show the subjective view, PSNR, misdetection rate and the complexity of computation data of the experimental results. The conclusion is given in Sec. 5.

2. Previous Work

Depth-Image-Based-Rendering for advanced 3D TV System can be illustrated by the following block diagram [2] [3].

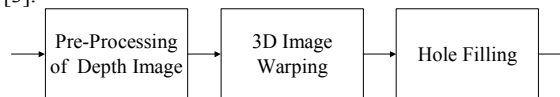

Fig.1. DIBR System Block Diagram

This system includes three parts, pre-processing of depth map, 3D image Warping and Hole-Filling. Smoothing filter is first applied to smooth the depth image. Then 3D image warping generates the left and right view according to the smoothed depth map and intermediate view. If there are still holes, hole-filling is applied to fill color into these holes.

2.1. Pre-Processing of Depth Image

Pre-Processing of depth image is usually a smoothing filter. Because depth image with horizontal sharp transition would result in big holes after warping, smoothing filter is applied to smooth sharp transition so as to reduce the number of big hole.

However, if we blur the whole depth image, we will not only reduce big holes but also degrade the warped view. This is

because the depth map of non-hole area is smoothed. We will show the subjective view and PSNR degradation in section 4.

2.2. 3D Image Warping

3D image warping maps intermediate view pixel by pixel to left or right view according to pixel depth value. In the other words, 3D image warping transforms pixel location according to depth value. The 3D image warping formula is as following [3]:

$$\begin{aligned} x_l &= x_c + \left(\frac{t_x}{2} \frac{f}{Z}\right), \\ x_r &= x_c - \left(\frac{t_x}{2} \frac{f}{Z}\right) \end{aligned} \quad (1)$$

The x_l is the horizontal coordinate of the left view, and x_r is the horizontal coordinate of the right view. Besides, x_c is the horizontal coordinate of the intermediate view. Z is depth value of current pixel, f is camera focal length and t_x is eye distance.

The formula shows that 3D warping maps pixel of intermediate view to left and right view in horizontal direction.

2.3 Hole Filling

Average filter interpolation method is a common method for Hole-Filling in DIBR. However, using average filter only would result in artifacts at highly-textured areas. Besides, hole-size in DIBR is so huge that it is needed to using average filter with large window size. At the same time, average filter with large window size can not preserve edge information for the reason that edge information is blurred.

The formula used to do Hole-Filling is as below:

$$\frac{\sum_{v=-w}^{v=w} \left\{ \sum_{\mu=-w}^{\mu=w} s(x-\mu, y-v) \times non_hole(x-\mu, y-v) \right\}}{\sum_{v=-w}^{v=w} \left\{ \sum_{\mu=-w}^{\mu=w} non_hole(x-\mu, y-v) \right\}} \quad (2)$$

$$non_hole(x, y) = \begin{cases} 0 & \text{If } (x, y) \text{ is a hole} \\ 1 & \text{Otherwise} \end{cases} \quad (3)$$

If the current pixel is a hole, we will use the above formula to add color into the hole. w is window size.

3. Proposed Method

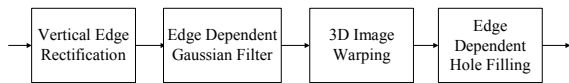

Fig.2. The proposed DIBR System

The main problem which we want to solve in DIBR system is to reduce the number of big hole while keeping the PSNR and subjective view quality. Besides, the computation time is too large in the previous methods. Therefore, the proposed method also aims at computation aware DIBR system.

There are three features in the proposed method: edge dependent depth filter, edge oriented interpolation, and vertical edge rectification.

3.1. Edge Dependent Depth Filter

In the previous method [3], pre-processing of depth map is used to reduce the number of big hole. Then we can interpolate the small holes by average filter with smaller window size. Thus Hole-Filling can achieve better interpolation performance at high complexity area. For reducing the number of big hole, only horizontal edge area needs to be smoothed. However, the previous method smooths not only the horizontal edge area but also the homogeneous area. Therefore, the previous method degrades the non-hole area. The reason is that the homogeneous area in intermediate depth map would not cause holes after warping. Besides, the depth value is assumed to be true. Therefore, we hope pre-processing of depth map would not modify the non-hole area. The proposed method detects the hole-location by special edge filter. And the pre-processing of depth map is operated on the detected edges. For left view, we smooth the low to high sharp depth transition in horizontal direction because only transition of low to high would result in holes. For right view, we smooth the high to low sharp depth transition in horizontal direction because only this transition would result in holes. By this method, we can reduce the occurrence of big holes and have good quality on subjective view and PSNR.

3.2. Edge Oriented Interpolation

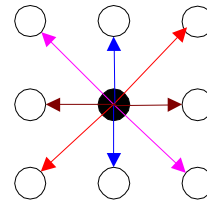

Fig.3 Edge Dependent Edge Filter

The edge dependent interpolation method is proposed to preserve edge information of the interpolated area. Average filter is commonly used to do Hole-Filling, but it can not preserve edge information of the interpolated area. We modified the ELA interpolation method [6] for Hole-Filling. We interpolates small hole along the edge, thus the edge information of the interpolated area is preserved.

The edge dependent interpolation method detects the minimal intensity difference of the four directions and interpolates the central hole with average of the pixel value of the two pair with minimum difference.

3.3. Vertical Edge Rectification

Vertical edge rectification will provide depth accuracy along vertical line. If a vertical line is given with inconsistent depth value along the line, the line in the warped view will become branching. This defect is shown Fig.4.

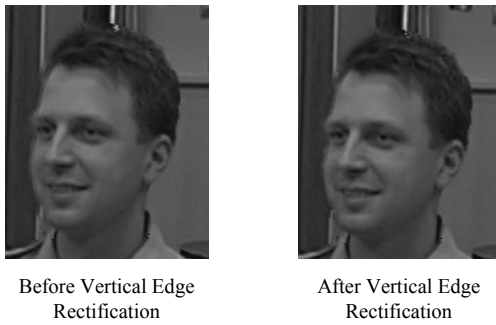

Fig.4

To solve this problem, we proposed the depth rectification for vertical edge near object boundary. This method detects vertical line near object boundary. If the vertical line depth value is inconsistent near boundary, the depth value is adjusted to a consistent value.

4. Results

Results have been simulated by software with C language. Subjective view, CPU instruction cycles, misdetection number, hole number reduction rate, Objective PSNR results are discussed in this section.

4.1. Subjective View Comparison

In Fig.5, we show simulated results of one frame in our test sequence. (a) is Intermediate view and (b) is depth map of intermediate view. We use intermediate view and depth map to generate left and right view. The technique is so called DIBR technology.

Fig.6 shows that the proposed method would not have the same rubber and sheet artifact at the left of face. Besides, we can see that the result of (c) has curved line on the man's head. The proposed method does not have the same defect.

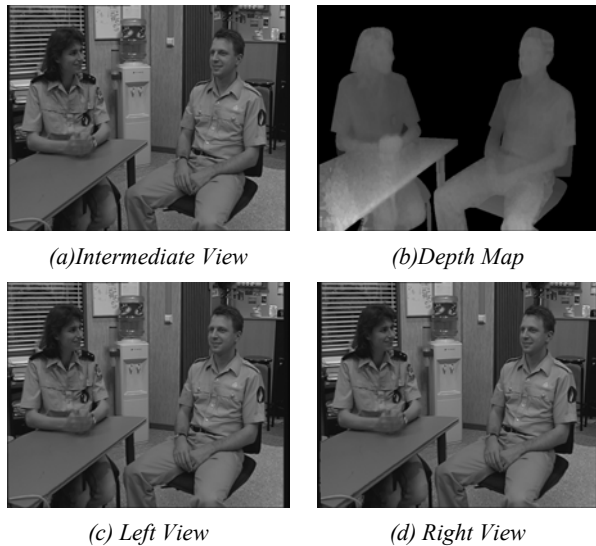

Fig.5 The proposed result

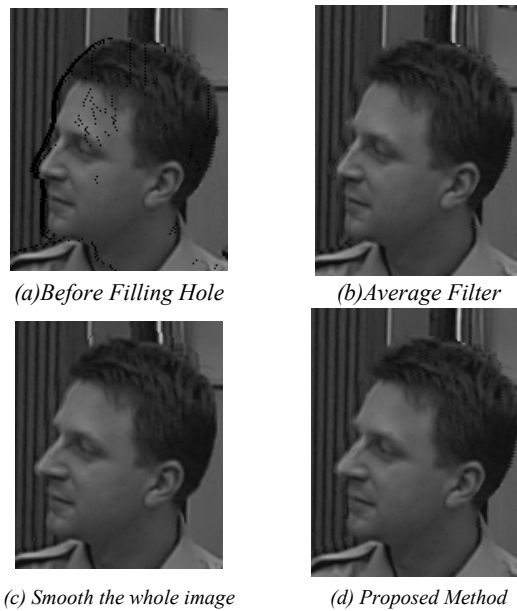

Fig.6 Subjective View Comparison

4.2. Computation Cycle Comparison

The environment we run the computation cycles simulation is as following: We use Intel P4 Xeon 2.8GHz with 1GB RAM. The operation system is Linux 2.4.18. The comparison result is showed by the following table.

Table1.Computation Cycle Comparison

| | No Blur depth image | Blur the whole depth | The proposed method |
|------------|---------------------|----------------------|---------------------|
| GIPS | 4.28 | 190.56 | 7.08 |
| Percentage | 2.25% | 100% | 3.71% |

Table 1 shows that the proposed method can reduce the number of instruction cycles to 3.7% compared with the previous work.

4.3. Misdetection Number

The definition of misdetection number is the number that the pixel is originally not a hole pixel but becomes a hole pixel after pre-processing of depth map. Fig.7 shows that our method can reduce the misdetection number.

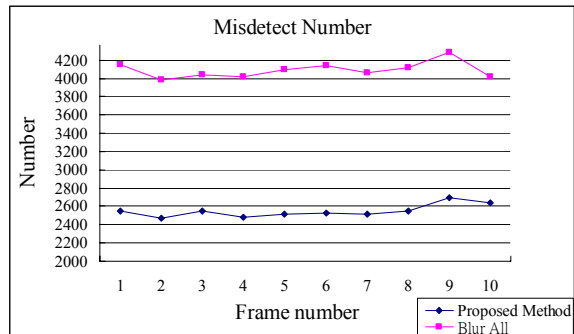

Fig7.Misdetection Numbers Comparison

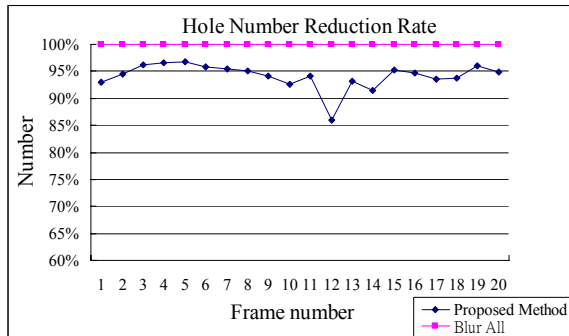

Fig.8 Hole Number Reduction Rate

4.4. Hole Number Reduction Rate

Hole number reduction rate represents the ability to reduce big holes. The definition of big holes is the hole with more than 1 hole-length. Hole-length is the pixel number of a hole in horizontal direction. If the hole-length of a hole is bigger or equal to 2, the hole has to be filled with interpolation filter with larger window size. Thus the edge information of such area is hard to preserve. Gaussian filter is used to reduce the number of big holes. The Fig.8 shows that the hole-number with length bigger than 1 is reduced 92% by the proposed method while the previous work achieves 100% reduction. In spite of that, the reduction rate of the proposed method is quite high. We can see the subjective view result to understand the reduction rate is high enough to achieve good interpolation quality.

4.5. PSNR Comparison

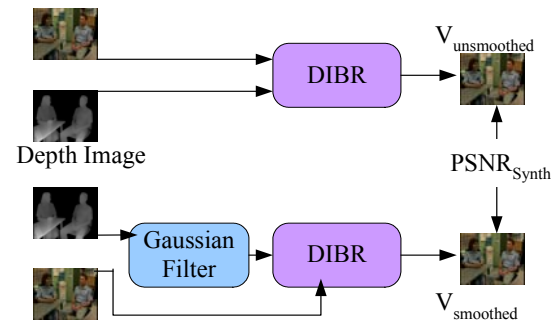

Fig.9.The PSNR Comparison System

The PSNR comparison model is similar to the PSNR model in [5]. This model is used to evaluate the synthesized view quality. In Fig.9, first we use the original intermediate view and depth image to synthesize left or right view. At the same time, we derive a mask which shows where the non-hole area is by the proposed edge dependent filter. Then the non-hole area can be warped from accurate depth map. Because the non-hole area is assumed accurate image area, what we have to do is interpolate the hole-area without degrading the non-hole area. Therefore we evaluate the

PSNR quality by comparing the non-hole area warped from original depth image with the same area warped from smoothed depth image. The compared result shows that the proposed method can achieve better image quality at the non-hole area. Fig.10 shows that the proposed method is better than previous work by 6 dB.

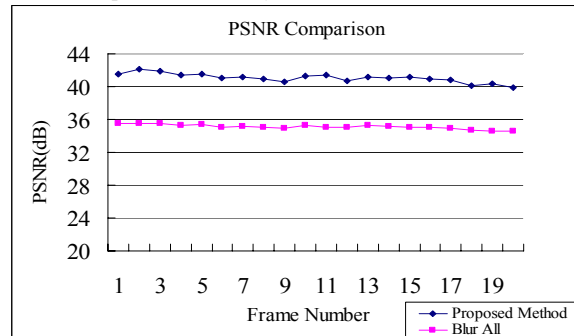

Fig.10 The PSNR Comparison result

5. Conclusion

DIBR has an essential problem of filling holes. In this paper we fill the holes without defects by edge dependent Gaussian filter and interpolation. The subjective view and simulation result shows that we can reach better quality than the previous work. In addition to that, the number of instruction cycle for DIBR is reduced to 3.7 percent in comparison to previous work.

6. Reference

- [1] A. Redert, M. Op de Beeck, C. Fehn, W. IJsselsteijn, M. Pollefeys, L. Van Gool, E. Ofek, I. Sexton, P. Surman, "ATTEST –advanced three-dimensional television system techniques", *Proc. of 3DPVT' 02*, Padova, Italy, Jun. 2002. pp. 313-319
- [2] C. Fehn, K. Hopf and Q. Quante, "Key Technologies for an Advanced 3D-TV System " *In Proceedings of SPIE Three-Dimensional TV, Video and Display III*, Philadelphia, PA, USA, October 2004. pp. 66-80.
- [3] Chung J. Kuo, Ching Liao, and Ching C. Jin, "STEREOSCOPIC IMAGE GENERATION BASED ON DEPTH IMAGES", *ICIP*, Singapore, October. 2004, pp. 2993-2996
- [4] C. Fehn "Depth-Image-Based Rendering (DIBR), the compression and Transmission for s New Approach on 3D-TV." *In Proceedings of SPIE Stereoscopic Displays and Virtual Reality Systems XI*, San Jose, CA, USA, January 2004. pp. 93-104
- [5] K. Schüür, C. Fehn, P. Kauff and A. Smolic, "About the Impact of Disparity Coding on Novel View Synthesis." *ISO/IEC JTC 1/SC 29/WG 11, MPEG02/M8676*, Klagenfurt, Austria, July 2002.
- [6] T. Doyle, "Interlaced to Sequential Conversion for EDTV Applications," *in Proc. 2nd International Workshop Signal Processing for HDTV*, Feb. 1988, pp.412-430